

Thank you for choosing a NIVELCO instrument.  
We are sure that you will be satisfied throughout its use.

USER'S MANUAL



Manufacturer:  
**NIVELCO Process Control Co.**  
1043 Budapest, Dugonics u. 11.  
Phone: (36-1) 889 - 0100 ♦ Fax: (36-1) 889 - 0200  
e-mail: sales@nivelco.com ♦ www.nivelco.com

**1. APPLICATION**

NIVOSWITCH R-300 series vibrating forks are for level detection of powder, lumpy solids and granules. Overfilling and emptying of silos or vessels can be prevented when using them as high or low fail safe switches. The RC series (basic type insertion length = 125 mm) with casted forks are recommended for small granules, while the RL series (basic type insertion length = 137 mm) with welded forks are recommended for larger granules. Both RC and RL series are also available in dust Ex versions.

**2. TECHNICAL DATA**

**2.1 GENERAL DATA**

TYPE		R □ □ - 3 □ □ - □
Medium pressure		40 bar, 6 bar with PP flange See Derating diagram
Insertion length		0.125 ... 3 m
Material of wetted parts		Casted fork DIN 1.4404, welded fork DIN 1.4571
Medium temperature		-40 °C ... +130 °C, See Derating diagram
Ambient temperature		-40 °C ... +70 °C, See Derating diagram
Medium		$\rho \geq 0.01 \text{ kg/dm}^3$
Switching delay	Getting immersed	0.5 sec
	Getting free	$\leq 1 \text{ s}$ – selected high density (H) ( $\rho \geq 0.5 \text{ kg/dm}^3$ ) $\leq 3 \text{ s}$ – selected high density (L) ( $\rho < 0.5 \text{ kg/dm}^3$ )
Indication of operation		Bi-colour LED
Test of operation		Output state can be changed with test magnet

**2.2 TWO-WIRE DC VERSION**

TYPE	2-WIRE DC	
	R □ □ - 3 □ □ - 6	R □ □ - 3 □ □ - 7
Electric connection	Connector	3 m cable (2 x 0.5 mm <sup>2</sup> )
Ingress protection	IP 65	IP 68
Output	DC current change: fork free: $9 \pm 1 \text{ mA}$ ; fork immersed: $14 \pm 1 \text{ mA}$	
Power consumption	$< 0.5 \text{ W}$	
Supply voltage	15 ... 27 V DC	
Selection of operation	LOW fail safe L or HIGH fail safe H on suggested isolator, by switch	
Selection of sensitivity	By inverting the polarity of connection	
Electric protection	Class III	

**2.3 TWO-WIRE AC, THREE-WIRE DC VERSION**

TYPE	2-WIRE AC		3-WIRE DC	
	R □ □ - 3 □ □ - 1	R □ □ - 3 □ □ - 2	R □ □ - 3 □ □ - 3	R □ □ - 3 □ □ - 4
Electric connection	connector	3 m cable, 4 x 0.75 mm <sup>2</sup> max. cable length. 30 m	connector	3 m cable 5 x 0.5 mm <sup>2</sup> max. cable length 30 m
Ingress protection	IP 65	IP 68	IP 65	IP 68
Selection of operation (Low fail safe - L, High fail safe - H)	By altering the connection		By switch on the cover	By inverting the polarity of connection
Selection of density. (low density- L, high density - H)	Not possible $\rho \geq 0.5 \text{ kg/dm}^3$		By switch on the cover	With wiring
Output	serial AC output		By changing polarity NPN- and PNP transistor switch	Galvanically isolated PNP/NPN transistor switch
Output protection	—		changing polarity, overvoltage, short cut	
Supply voltage	20 ... 255 V AC, 50/60 Hz		12 ... 55 V DC	
Power consumption	Depending on load		$< 0.6 \text{ W}$	
Voltage drop between terminal points during operation	$< 10.5 \text{ V}$		0...1.8 V	
Electric protection	Class I		Class III	
Current load	max. continuous	350 mA AC 13, for Ex version (C, D) 140 mA	$I_{\text{max}} = 350 \text{ mA}$ for Ex version 200 mA DC / $U_{\text{max}} = 55 \text{ V DC}$	
	min. continuous	10 mA / 255 V. 25 mA / 24 V	—	
	max. impulse	1.5 A / 40 ms	—	
Residual current after switch off	$< 6 \text{ mA}$		$< 10 \mu\text{A}$	
Mark of explosion protection	Ⓔ II ½ D IP 65 T 160°C for C, E output codes, Ⓔ II ½ D IP 68 T 160°C for D, F output codes			

**2.4 ACCESSORIES**

- User's Manual
- Declaration of Conformity
- Gasket 2 mm klingerit (KLINGER OILIT) ring (1 pc)
- Certificate of Warranty
- RPS-101 type screw driver with test magnet (optional)
- Sliding sleeve: RPH-112 (optional)

**2.5 ORDER CODE**

NIVOSWITCH R □ □ - 3 □ □ - □ \*

TYPE	CODE	CONNECTION	CODE	CONNECTION	CODE	INSERTION LENGTH	CODE	OUTPUT	CODE		
Casted fork	C	1" BSP	M	2" ANSI RF 600 1.4571	B	125 / 137 mm	01	2-wire AC+ connector	1		
Welded fork	L	1½" BSP	H	JIS 10K 50 A PP	J	200 / 175 mm	02	2-wire AC + cable	2		
		1" NPT	P	JIS 40K 50 A 1.4571	K	0.3 ... 3 m	03...30	3-wire DC + connector	3		
		1½" NPT	N	1½" Triclamp	T			3-wire DC + cable	4		
		DN50 PN 16 PP DIN	F	2" Triclamp	R			2-wire DC+ connector	6		
		DN50 PN 40 1.4571 DIN	G	Pipe coupling DN 40	D	2-wire DC + cable	7				
		2" ANSI RF150 PP	A	Pipe coupling DN 50	E	<b>Dust Ex</b>		2-wire AC+ connector	C		
										2-wire AC + cable	D
										4-wire DC+ connector	E
										2-wire DC + cable	F

\* The order code of an Ex version should end is 'Ex'

## 2.6 DERATING DIAGRAMS

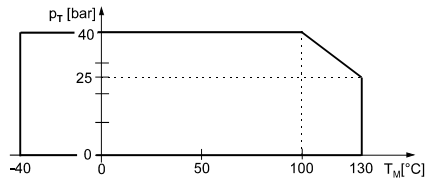

Tank pressure ( $p_T$ ) versus the ambient temperature ( $T_M$ )

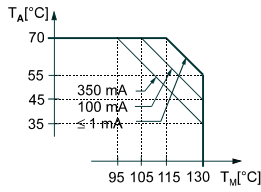

Temperature limits for DC devices [ $I_L$ ] Current load [ $T_A$ ] ambient temperature

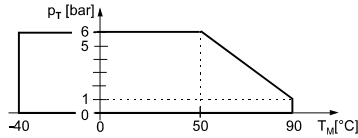

Tank pressure ( $p_T$ ) versus ambient temperature ( $T_M$ ) for PP flange

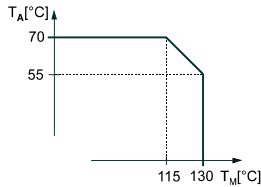

Temperature limits AC [ $T_A$ ] ambient temperature [ $T_M$ ] medium temperature

## 2.7 DIMENSIONS

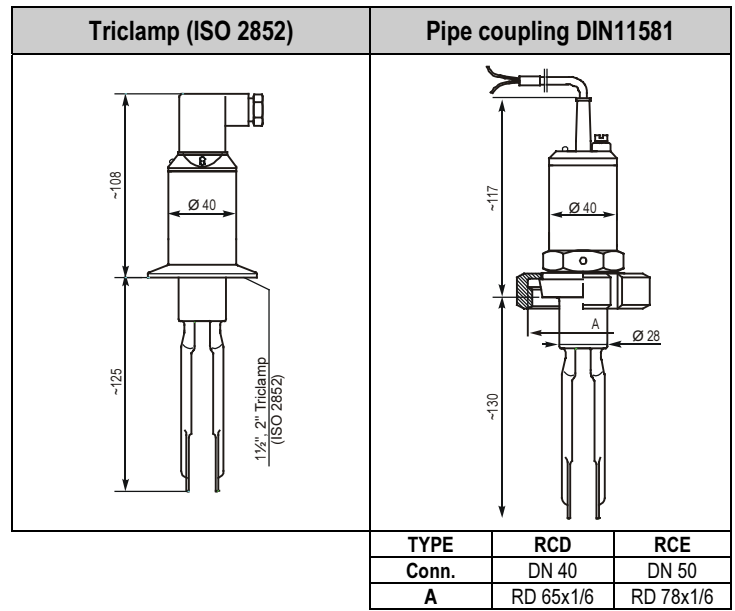
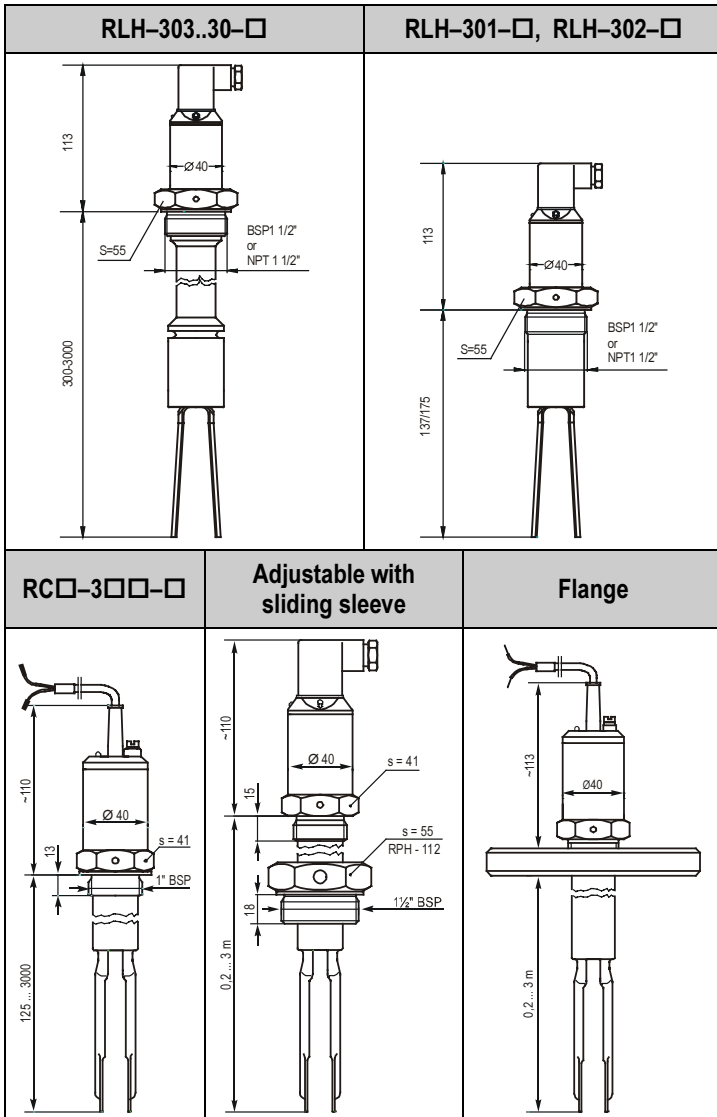

## 2.8 MATERIALS

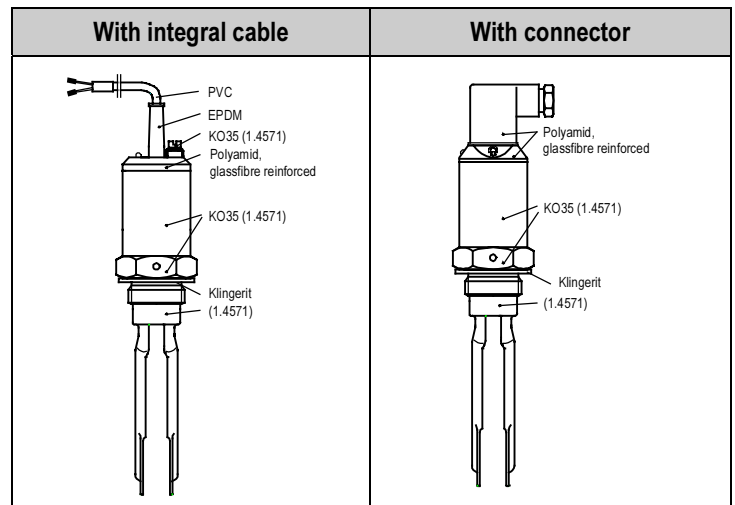

## 3. MOUNTING

Prevent device from being damaged during delivery, storage, mounting and test.

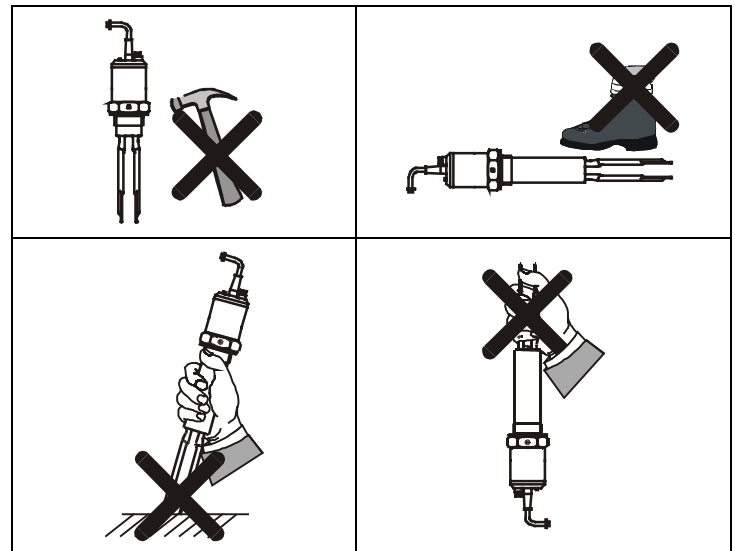

Before installation it is advised to try the operation of the level switch in a small sample of material in order to set the proper density. Tightening of the model with thread process connection should only be done with open end SW = 41

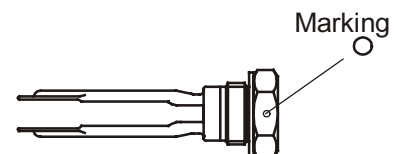

For positioning of the fork tine use the marking on the hexagonal neck.

The recommended mounting position of the fork for light, free flowing solids, is vertical (top) mounting. Side mounting is recommended only in cases when the fork-tines are easily freed from the process medium. In case of side mounting, NIVOSWITCH must be mounted with the fork-tines standing vertically.

When determining mounting location, take into account the possible caving or arching of the material in the tank.

The fork should be protected against falling materials. This is to be done so that material could not clog between the fork and the protection plate.

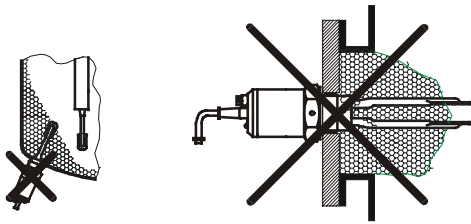
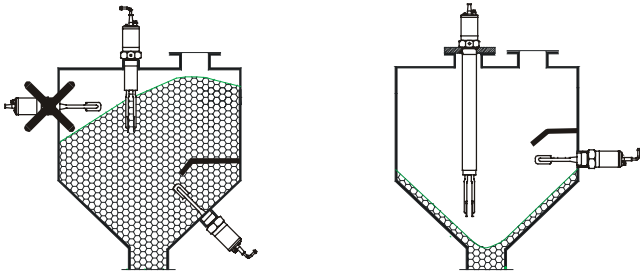

## 4. WIRING

### 4.1. TWO-WIRE AC

R □ □ - 3 □ □ - 1 with connector  
R □ □ - 3 □ □ - 2 with cable

**THE UNIT SHOULD NOT BE POWERED UP WITHOUT GROUNDING AND EXTERNAL LOAD!**

#### 4.1.1. Model with connector R □ □ - 3 □ □ - 1

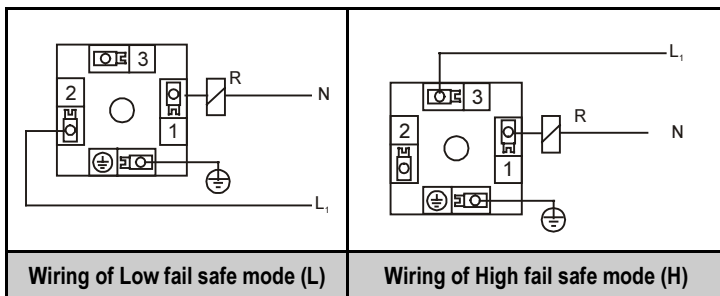

Terminal block cover can be rotated in 90° steps to ensure appropriate cable positioning.

#### 4.1.2. Integral cable version R □ □ - 3 □ □ - 2

Two of the signal wires (black and brown) are insulated. Only one of these two wires is used, depending on the operating mode (High or Low). Remove the insulation only from the wire corresponding to the desired operating mode.

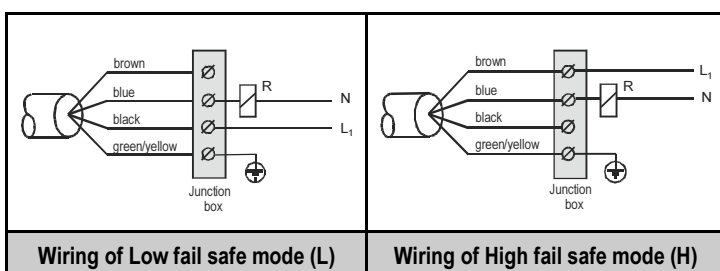

### 4.2. THREE-WIRE DC VERSION

R □ □ - 3 □ □ - 3  
R □ □ - 3 □ □ - 4

In case of overload caused by short circuit, the transistor will switch on and off, and the LED will start to blink.

#### 4.2.1. Connector version R □ □ - 3 □ □ - 3

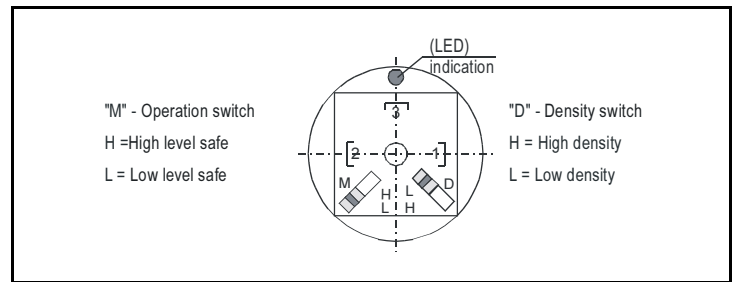

##### 4.2.1.1. Wiring diagram of the three-wire DC connector version with relay

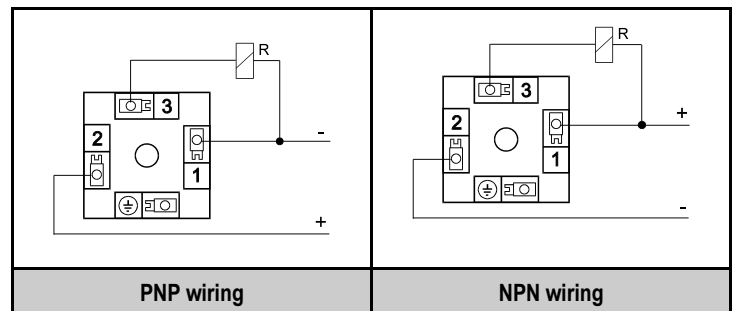

Terminal block cover can be rotated in 90° steps to ensure appropriate cable positioning.

##### 4.2.1.2. Wiring diagram of the three-wire DC connector version with PLC

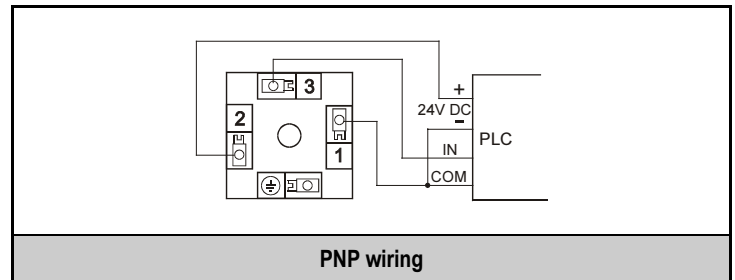

### 4.2.2. Integral cable version

R □ □ - 3 □ □ - 4

#### 4.2.2.1. Wiring with relay

PNP wiring high (H) density ( $\rho \geq 0.5 \text{ kg/dm}^3$ ),

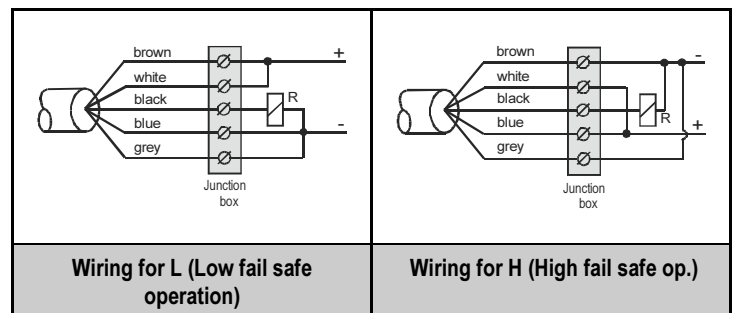

PNP output low (L) density, ( $\rho < 0.5 \text{ kg/dm}^3$ )

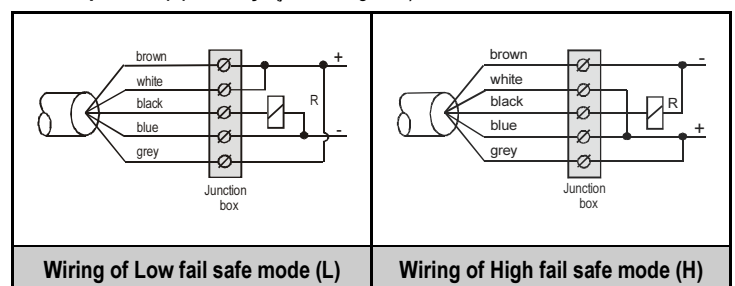

### NPN wiring high (H) density, ( $\rho \geq 0.5 \text{ kg/dm}^3$ )

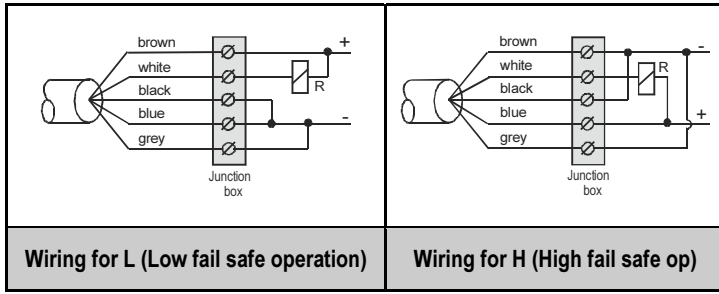

### NPN wiring low (L) density, ( $\rho < 0.5 \text{ kg/dm}^3$ )

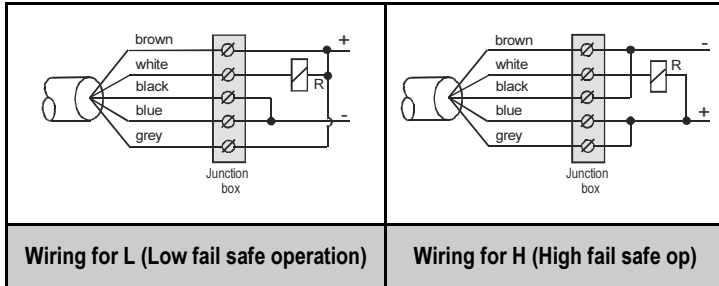

#### 4.2.2.2. Wiring with PLC

#### 4.2.2.3. PNP wiring high (H) density, ( $\rho \geq 0.5 \text{ kg/dm}^3$ )

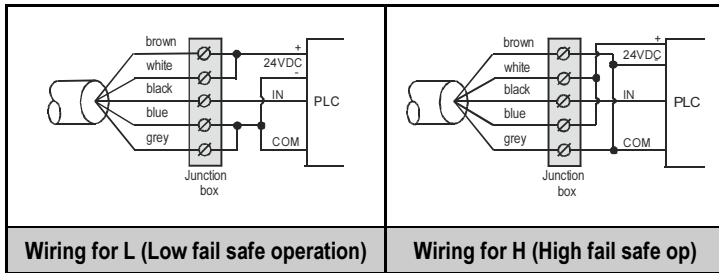

#### PNP wiring low (L) density, (for solids: $\rho < 0.5 \text{ kg/dm}^3$ )

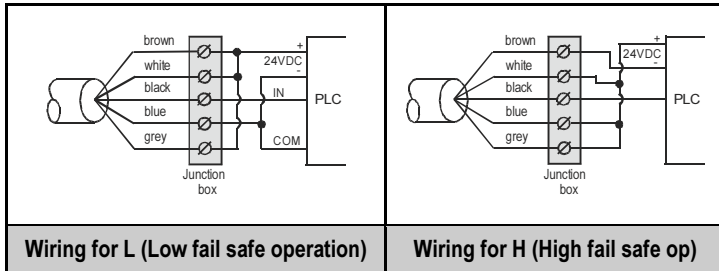

### 4.3. TWO-WIRE DC VERSION

#### 4.3.1. Connector version

R □ □ - 3 □ □ - 6

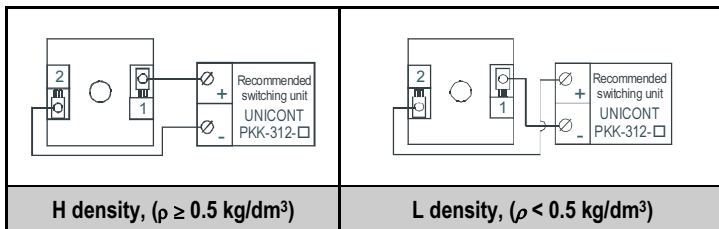

#### 4.3.2. Integral cable version

R □ □ - 3 □ □ - 7

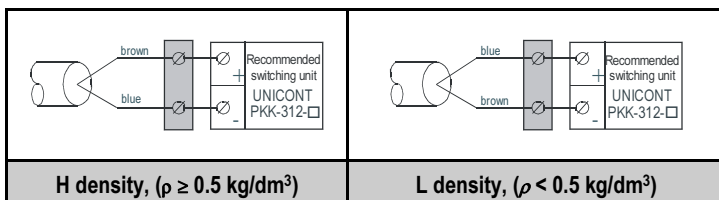

### 5. SET UP, ADJUSTMENT, PUTTING INTO OPERATION

Check wiring and setting of switches (if any). After powering up the vibrating fork is operational.

The operation is summarised in the table below.

Power supply	Fork	Operation	Indication (LED)	Output
YES	Immersed	H	RED	OFF
		L	GREEN	ON
	Free	H	GREEN	ON
		L	RED	OFF
NONE	Free or immersed	H or L	NONE	OFF

#### State of operation of the 2-wire DC version

Villa	Indication (LED)	Output
Immersed	RED	$14 \pm 1 \text{ mA}$
Free	GREEN	$9 \pm 1 \text{ mA}$

### OPERATION TEST

Operation of the switch can be verified with the help of the optional screwdriver with magnet (Type RPS-101).

When moving the magnet in front of the marking on the enclosure the state of the switch (colour of the LED) should be changed.

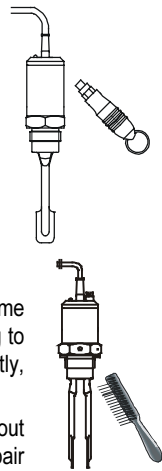

### 6. MAINTENANCE, REPAIR

The instrument does not require regular maintenance. In some instances, however, the probe may need occasional cleaning to remove surface deposits. This must be carried out gently, without harming the probe.

Repairs during or beyond the warranty period are carried out solely by the manufacturer. Equipment sent back for repair should be cleaned or sterilised by the User. The User must declare that the above has been carried out.

### 7. STORAGE CONDITIONS

Ambient temperature:  $-25$  to  $+60 \text{ }^\circ\text{C}$   
Relative humidity: max. 98%

### 8. WARRANTY

All NIVELCO products are warranted free of defects in materials or workmanship for a period of two years from the date of purchase, as indicated in the Certificate of Warranty.