

**Hydronix**

Digital Microwave Moisture Sensor for  
Organic and Biomass Materials

# Hydro-Probe XT



THE ORIGINAL – THE LEADERS – THE BEST

# Hydro-Probe XT

## Digital microwave moisture sensor for bins, silos and conveyors

The Hydro-Probe XT is a rugged, microwave moisture measurement sensor designed to be installed in bins, silos and conveyors in process control environments.

Measuring at 25 times per second and with on-board functionality such as signal processing and averaging, the Hydro-Probe XT accurately measures the moisture content of material as it flows over the ceramic faceplate. Remote configuration, calibration, diagnostics and firmware upgrades are simple using Hydronix Hydro-Com software. The linear output allows direct integration with any control system using industry standard interfaces.



## Features

- Digital technology provides precise linear moisture measurement.
- Advanced Digital Signal Processing provides a clear signal with rapid response.
- Choice of measurement modes for optimising sensor performance in a variety of applications and material types.
- The Averaging Mode provides a continuous “average” moisture over a batch.
- Averaging, “Bin Empty” and “High Moisture” Alarms and Signal Processing are performed internally by the sensor.
- The sensor is designed to suit the flow characteristics of the material.
- Fast response to changing conditions with 25 measurements per second.
- Remote communication with Hydro-Com software allows configuration of all sensor parameters including selection of sensor outputs, graphic traces of outputs, calibration of sensor readings and firmware upgrades.
- Consistent performance with no need for recalibration except for use with different materials.

## Angle of Sensor

Ensures continuous flow over the sensor

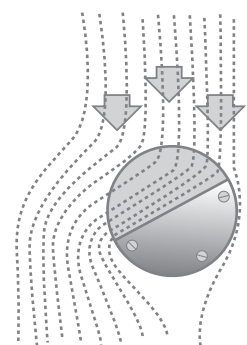

## Typical Installation

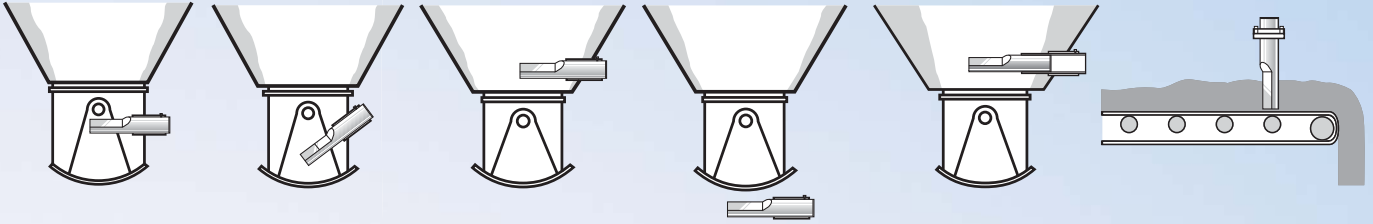

The Hydro-Probe XT offers a choice of installation options to suit all bin types and conveyor applications. This ensures that the sensor measures the most representative sample of material.

## Connectivity

### Digital Connection

Up to 16 Hydro-Probe sensors may be daisy chained to connect directly to a control system via the RS485 serial communications link.



### Direct Connection to Control System or PC

The analogue or RS485 serial interface integrates easily with a control system or PC.



### Hydro-View Connection

The Hydro-Probe can be connected to a Hydro-View to provide a continuous moisture display. It also enables the sensor to be easily calibrated if calibration facilities are not available on a PC or control system.



## Networking

Network up to 16 sensors using one standard Ethernet connection with the Ethernet Adapter Kit. Power over Ethernet option also available.



## USB Interface

Easily communicate with the sensor using a USB Sensor Interface Module for sensor diagnostics, configuration and firmware upgrades.



# Technical Information

## Construction

Body: Stainless Steel

Faceplate: Ceramic

## Fixing

The sensor must be placed in the flow of material.

Bins and Silos: Install in the neck of a bin or underneath the gate. Standard and Extension Mounting Sleeves are available to suit different bin widths.

Conveyors: Secure in the flow of material.

## Moisture Range

The sensor will measure up to saturation of material.

## Penetration of Field

Approximately 75-100mm dependant upon material.

## Refresh Rate

25 times per second.

## Operating Temperature

0-60° C. The sensor will not measure ice.

## Analogue Outputs

Two configurable 4-20mA or 0-20mA current loop source available for moisture and temperature. May also be converted to 0-10V DC.

## Digital (Serial) Communication

Opto-Isolated RS485 2-wire port. RS232, Ethernet and USB interfaces available.

Programming details to access sensor values and parameters are available on request.

## Discrete Inputs

The batch average, start, stop or moisture / temperature multiplexing functions can be controlled via the digital inputs.

## Extension Cable

Up to six twisted pairs, 22AWG, 0.35mm<sup>2</sup> conductors. Screen braid with 65% minimum coverage plus aluminium/polyester foil. Maximum cable run of 100m.

## Power Supply

+15V to +30V DC, 4W

## Configurable Alarms

The sensor can be set to signal "Bin Empty" or "Moisture Too High" levels.

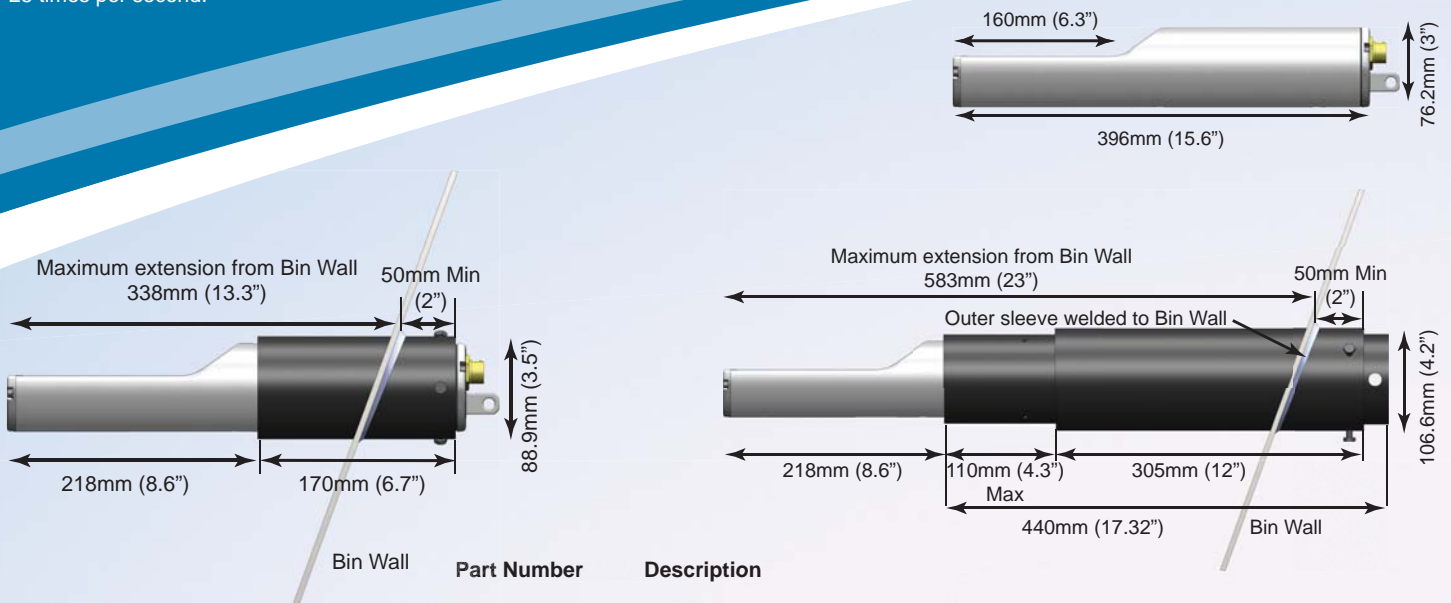

Bin Wall

## Part Number

## Description

HPXT	Hydro-Probe XT - Standard Mode for normal digital or analogue connection
0025	Standard Mounting Sleeve
0026	Extension Mounting Sleeve
0975	4m Sensor Cable with military specification sensor connector
0069	4m Compatibility Cable, 4 core with Bulgin Connector
0067	Terminal Box (IP66, 10 Terminals)
0116	24VDC Power Supply 30 watt for up to 4 Sensors
0049A	RS232-485 Adapter DIN rail mounting
0049B	RS232-RS485 Converter, 9 pin D-type to Terminal Block
SIM01-A	USB Sensor Interface Module including cables and power supply
EAK01	Ethernet Adapter Kit
EPK01	Ethernet Power Kit
PXEW	4 Year extended warranty option



# Hydronix

## Head Office - United Kingdom:

Tel: +44 (0)1483 468900

Fax: +44 (0)1483 468919

Email: [enquiries@hydronix.com](mailto:enquiries@hydronix.com)

## Central Europe:

Tel: + 49 2563 4858

## France:

Tel: + 33 652 04 89 04

## Americas:

Tel: 888-887-4884 (toll free)

or +1 231-439-5000

[www.hydronix.com](http://www.hydronix.com)

SL0025 1.0.0